

# Special hinge

- ▶ Markant 11 flap hinge
- ▶ For overlay flaps



- ▶ Flap hinge for overlay flaps
- ▶ Quality classification under EN 15828, Level 2
- ▶ Separate installation of bottom panel and flap element
- ▶ Flap alignment through adjustment of height, sides and depth
- ▶ Same drilling sizes in bottom panel and flap elements
- ▶ Hole drilling concealed by rim on both parts
- ▶ Without height adjustment, bottom panel and flap are flush on the inside when open
- ▶ Can only be used in conjunction with flap stays
- ▶ Zinc die-cast nickel plated

## Markant 11 flap hinge

Order no.	PU
0 040 242	1/20 ea.

### Mounting example

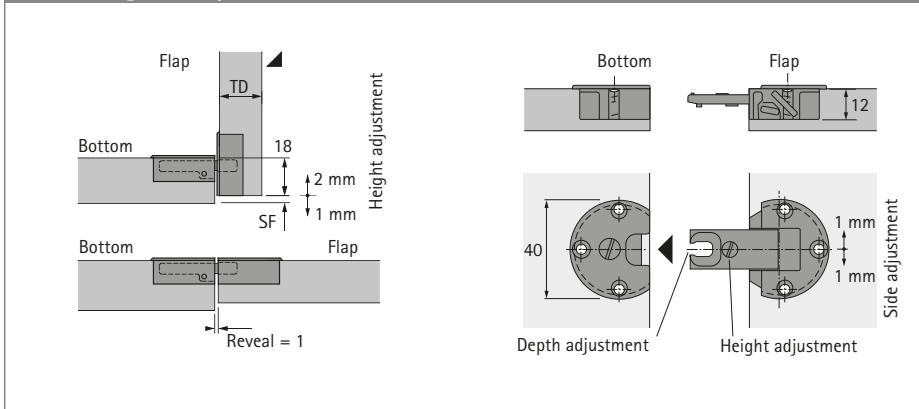

### Drilling pattern

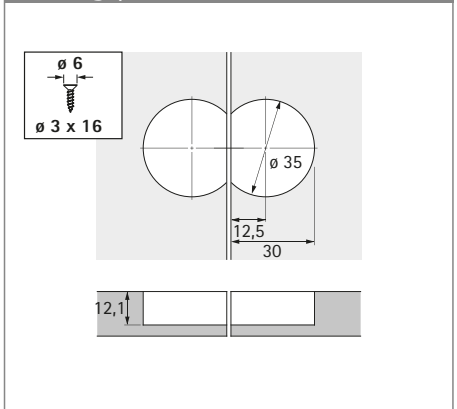

Flap thickness TD mm	Minimum reveal SF mm
16	1.0
17	2.0
18	3.0
19	3.5
20	4.5

### Note

